

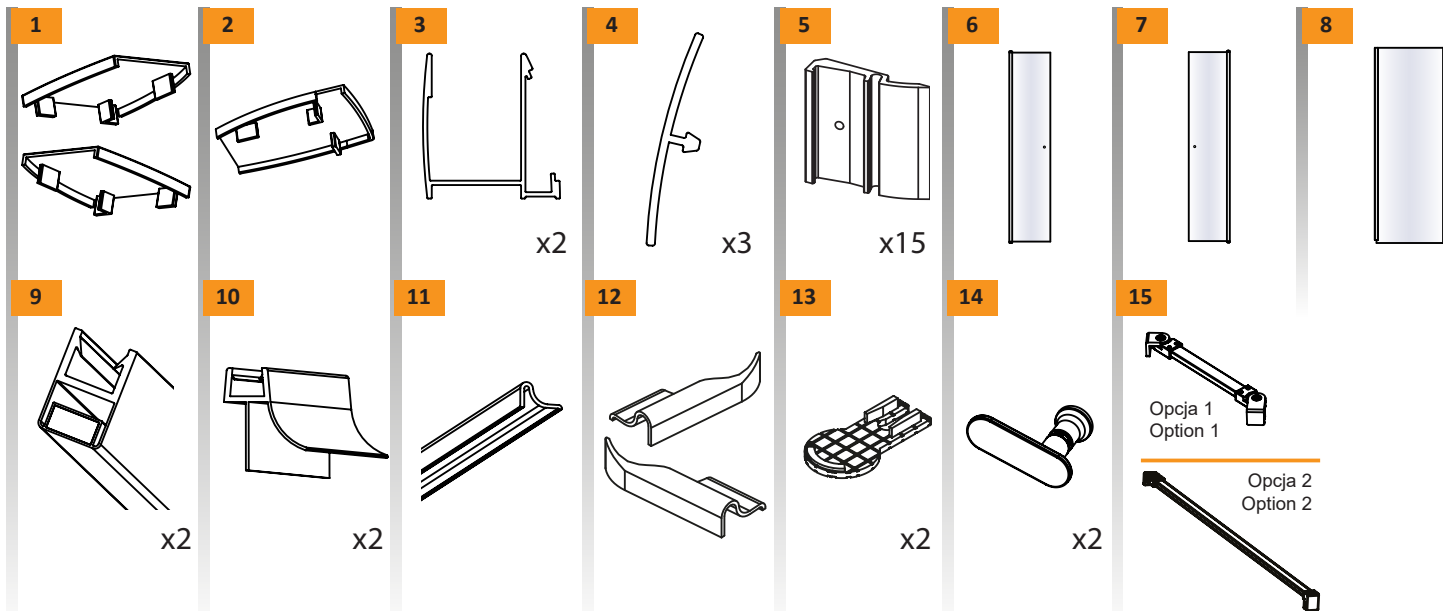

NEW SOLEO

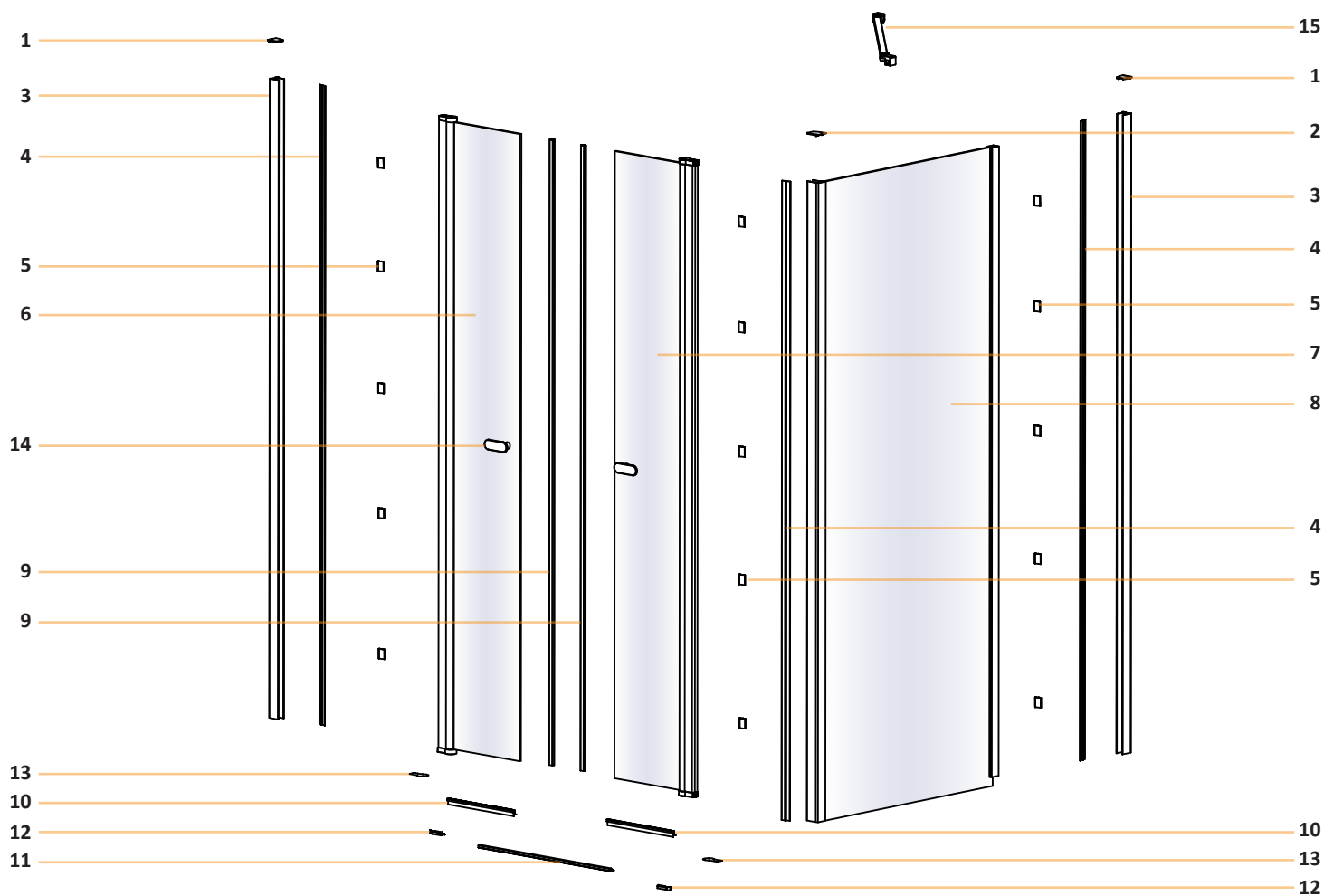

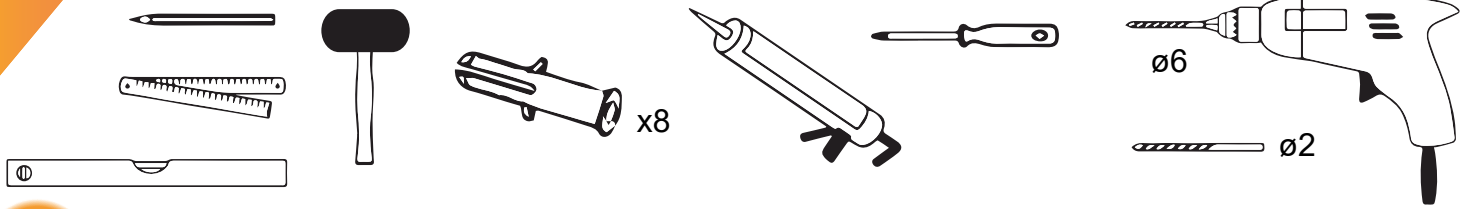

1

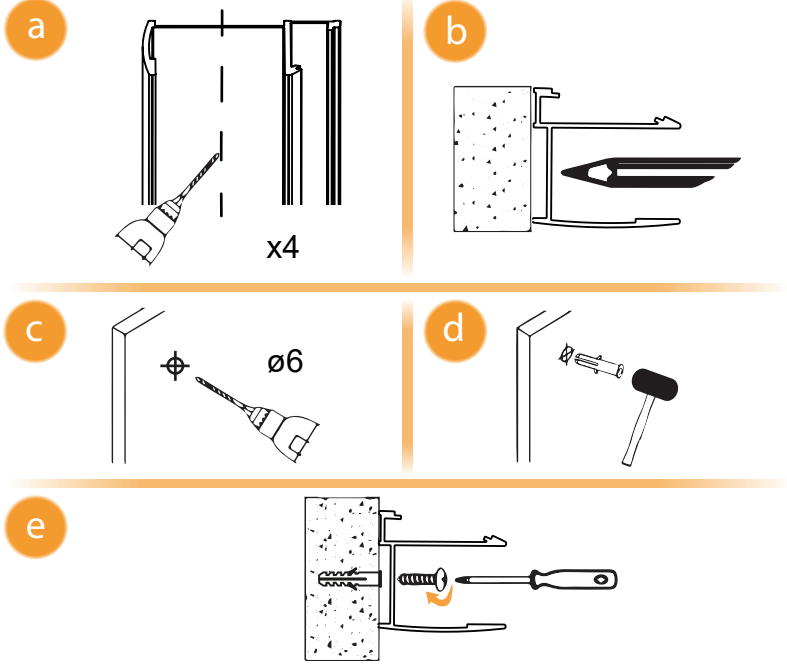
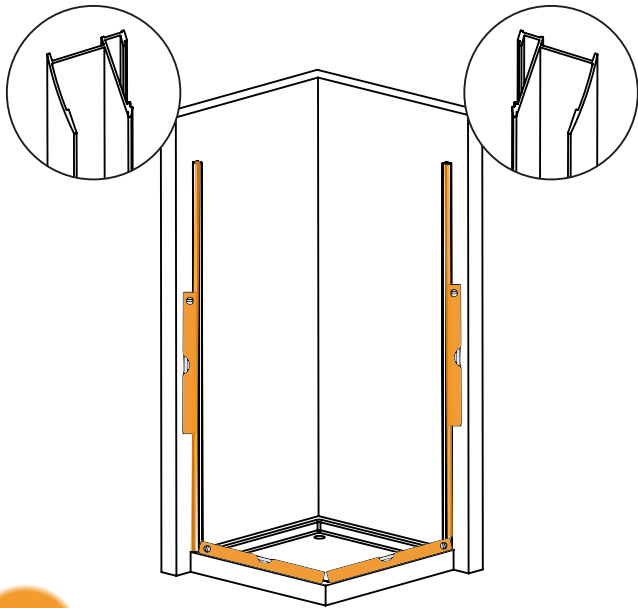

2

Drzwi LEWE
LEFT Door

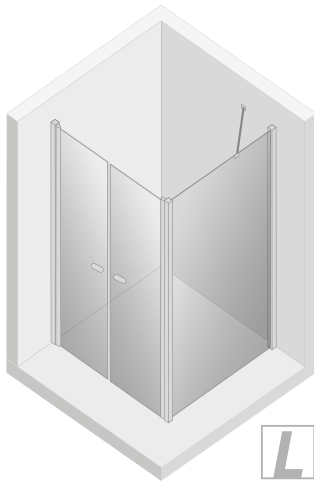

Drzwi PRAWE
RIGHT Door

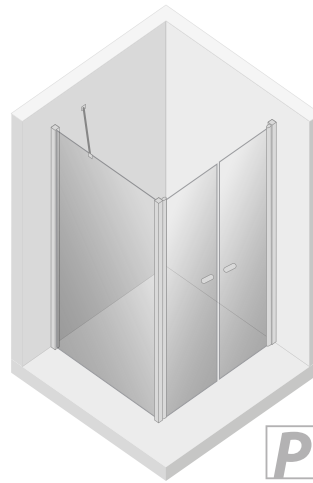

Opcja 1
Option 1
Wspornik
skośny
Strona 7

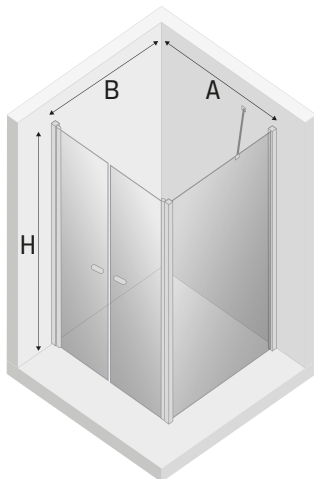

Opcja 2
Option 2
Wspornik
równoległy (WP)
Strona 7

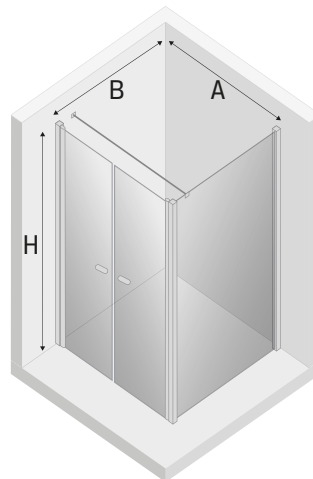



TABELA NIE DOTYCZY KABIN NA WYMIAR!
THE TABLE DOES NOT INCLUDE CUSTOM-MADE ENCLOSURES!

Specyfikacja techniczna **Kabin Na Wymiar** znajduje się w potwierdzeniu zamówienia.
The technical specification of the **Custom-Made Cabin** can be found in the order confirmation.

	Wymiary gabarytowe Overall dimensions		Wymiary do osi szyby Dimensions to the pane axis	
	A	B	X1	X2
70x70x195	70-71,2	69,5-71	68,7-70,2	68,2-69,7
70x80x195	70-71,2	79,5-81	68,7-70,2	78,2-79,7
70x90x195	70-71,2	89,5-91	68,7-70,2	88,2-89,7
70x100x195	70-71,2	99,5-101	68,7-70,2	98,2-99,7
80x70x195	80-81,2	69,5-71	78,7-80,2	68,2-69,7
80x80x195	80-81,2	79,5-81	78,7-80,2	78,2-79,7
80x90x195	80-81,2	89,5-91	78,7-80,2	88,2-89,7
80x100x195	80-81,2	99,5-101	78,7-80,2	98,2-99,7

	Wymiary gabarytowe Overall dimensions		Wymiary do osi szyby Dimensions to the pane axis	
	A	B	X1	X2
90x70x195	90-91,2	69,5-71	88,7-90,2	68,2-69,7
90x80x195	90-91,2	79,5-81	88,7-90,2	78,2-79,7
90x90x195	90-91,2	89,5-91	88,7-90,2	88,2-89,7
90x100x195	90-91,2	99,5-101	88,7-90,2	98,2-99,7
100x70x195	100-101,2	69,5-71	98,7-100,2	68,2-69,7
100x80x195	100-101,2	79,5-81	98,7-100,2	78,2-79,7
100x90x195	100-101,2	89,5-91	98,7-100,2	88,2-89,7
100x100x195	100-101,2	99,5-101	98,7-100,2	98,2-99,7

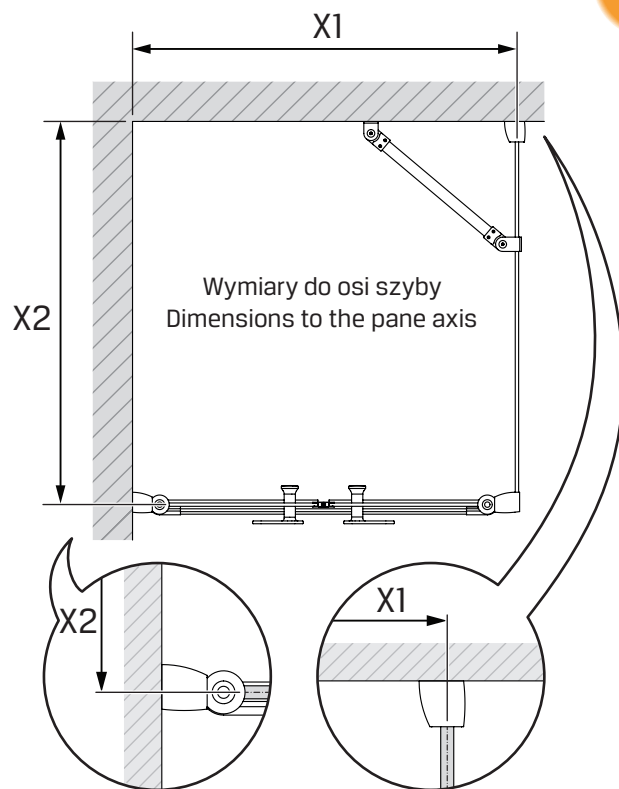
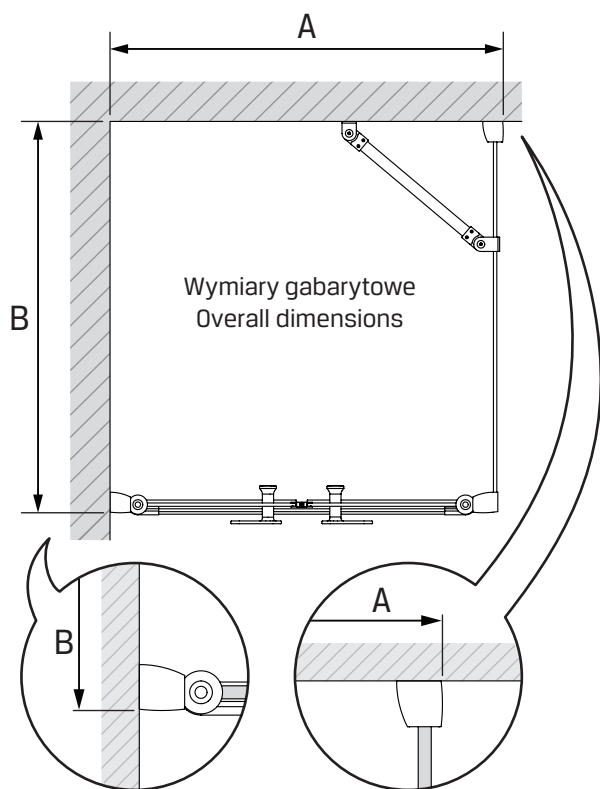
5

Active Shield
INSIDE

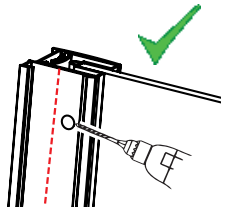
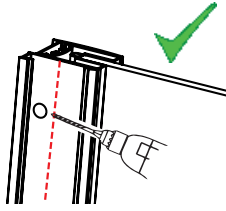
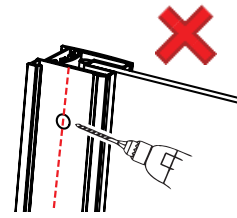
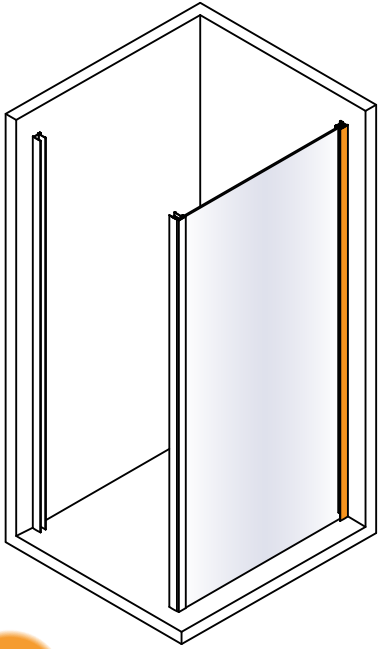

a

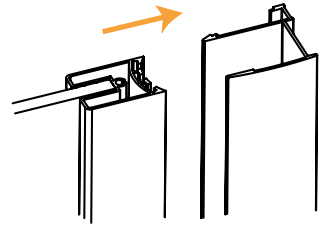

b

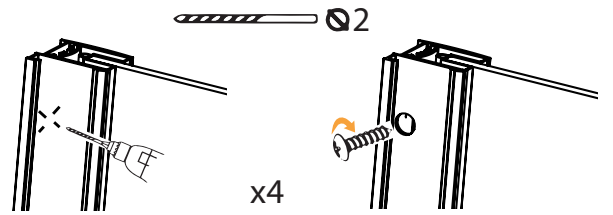

c

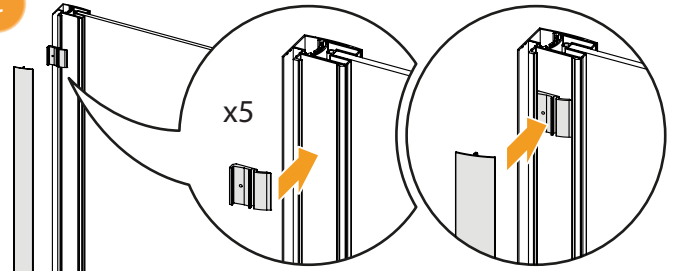

6

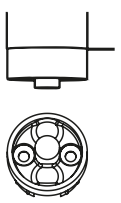
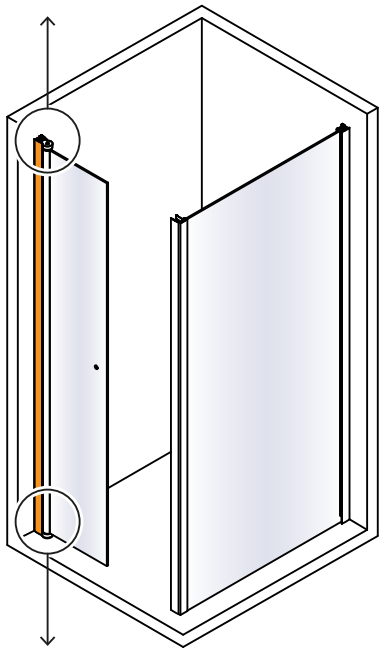
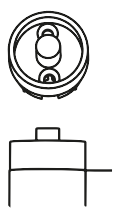

a

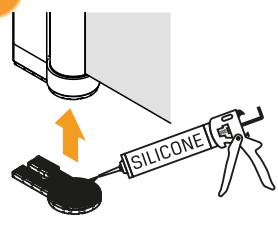

b

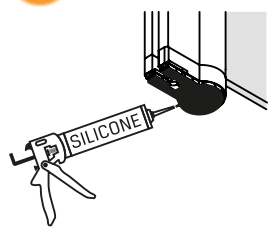

c

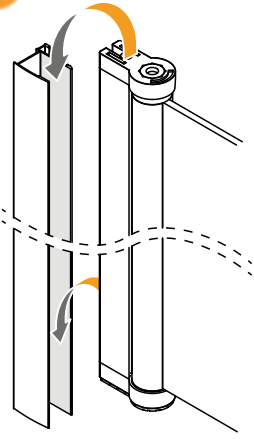

X

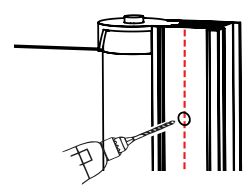

✓

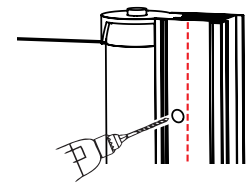

✓

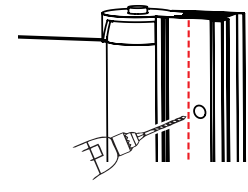

d

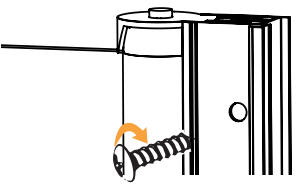
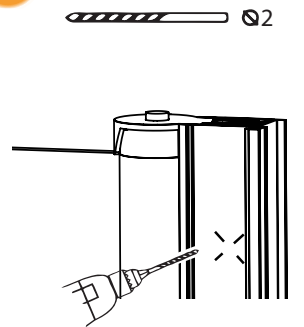

4x

e

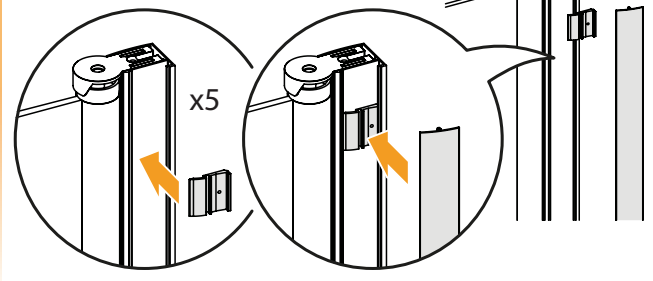

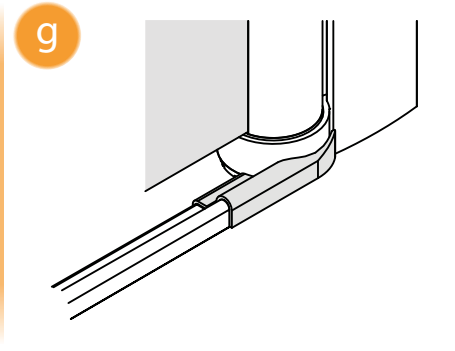
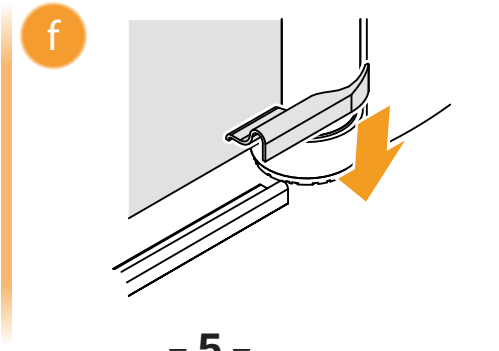
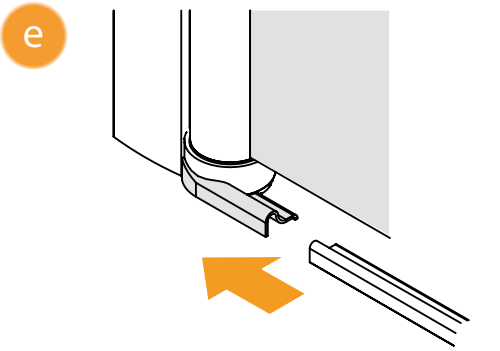
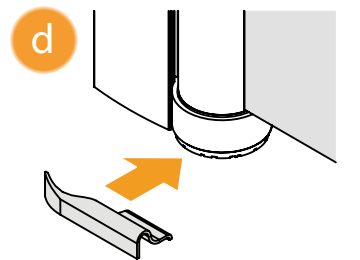
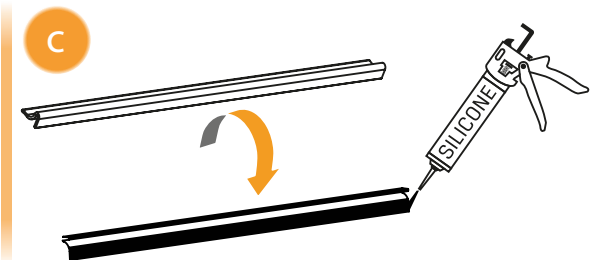
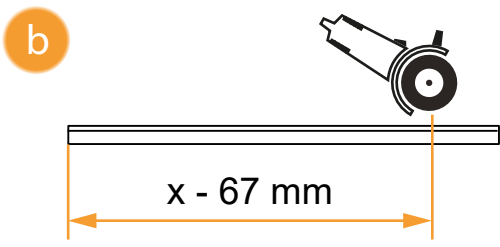
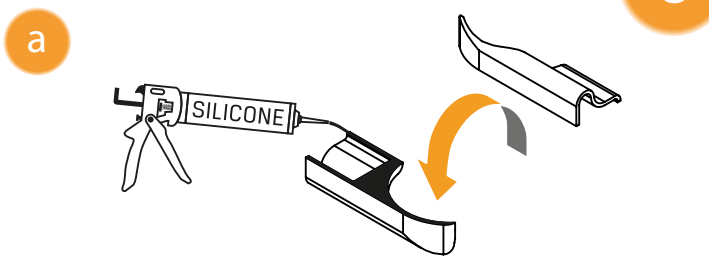
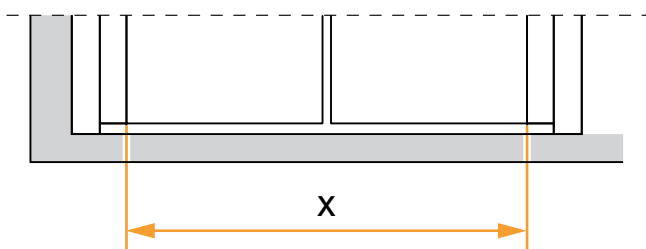
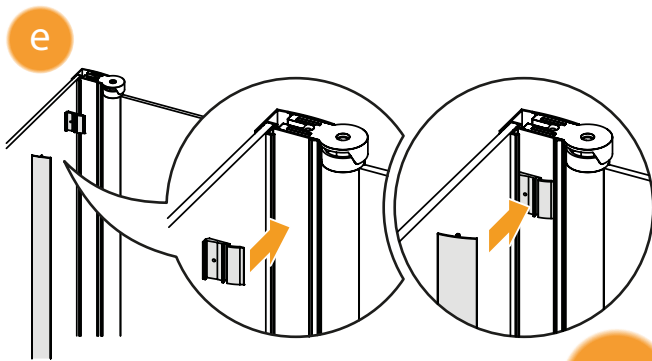
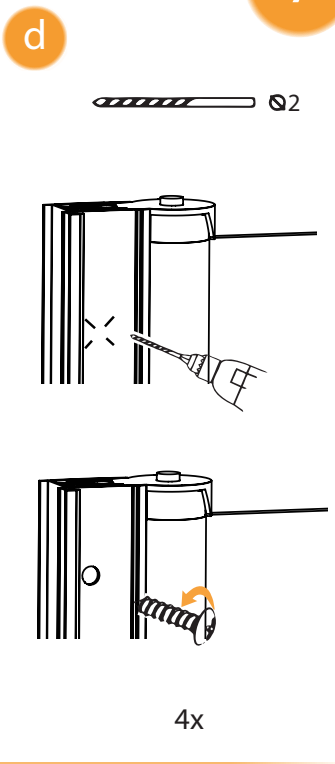
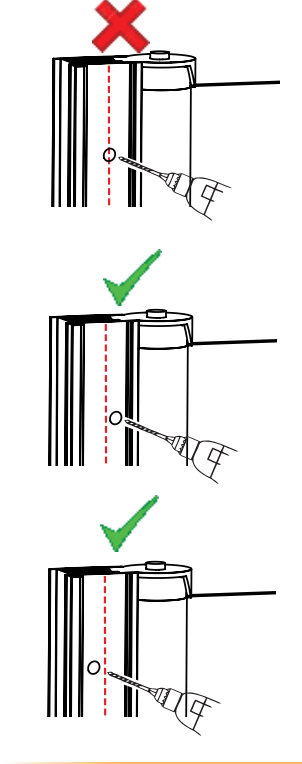
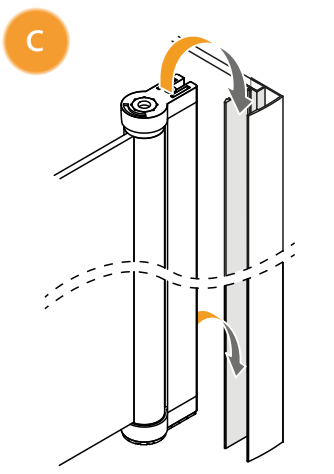
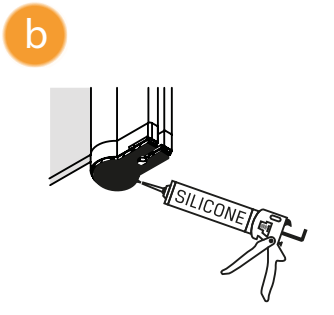
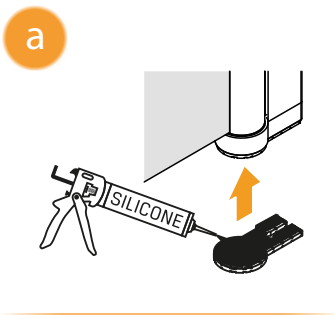
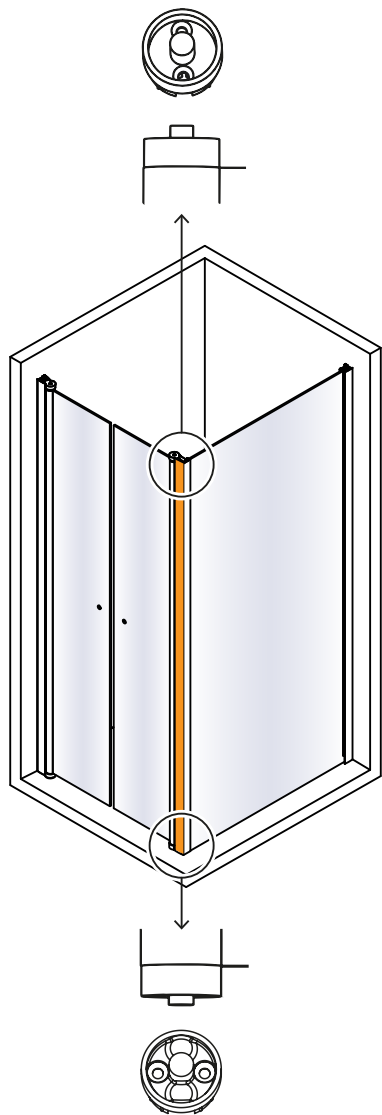

9

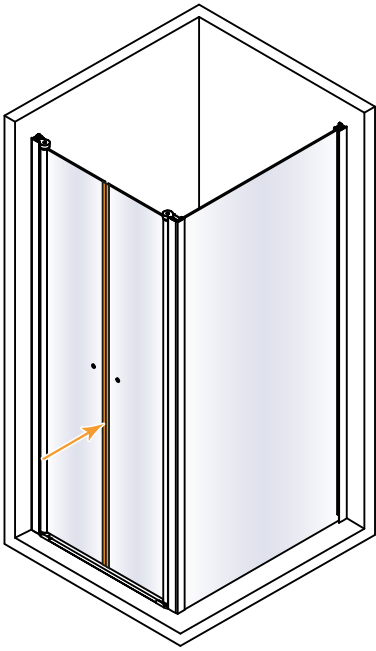

a

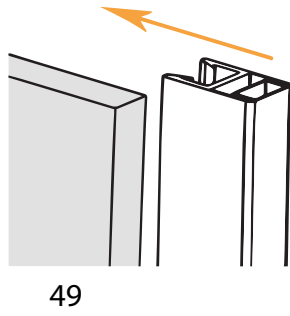

b

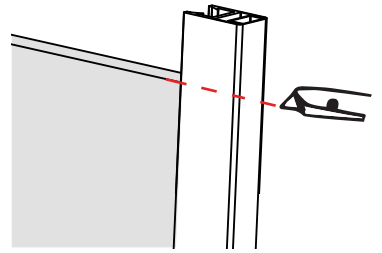

c

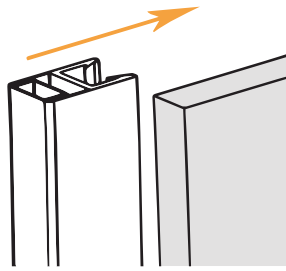

d

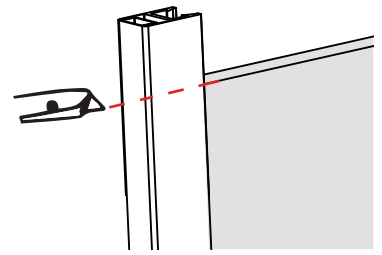

10

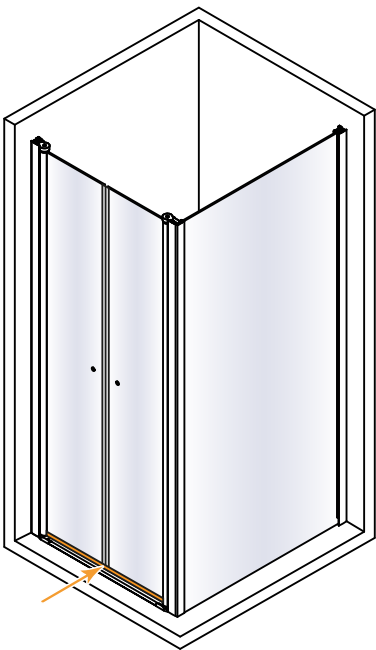

a

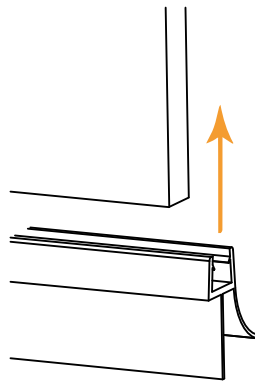

b

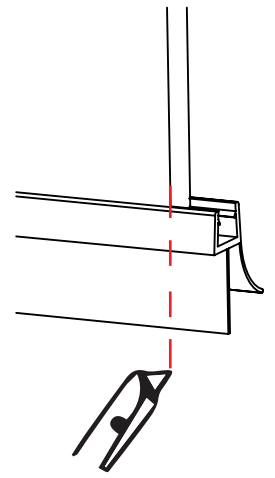

c

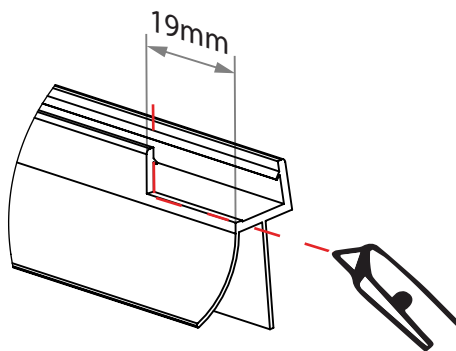

d

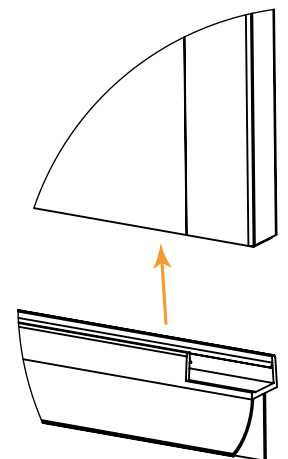

Opcja 1 - Option 1
(wspornik skośny)

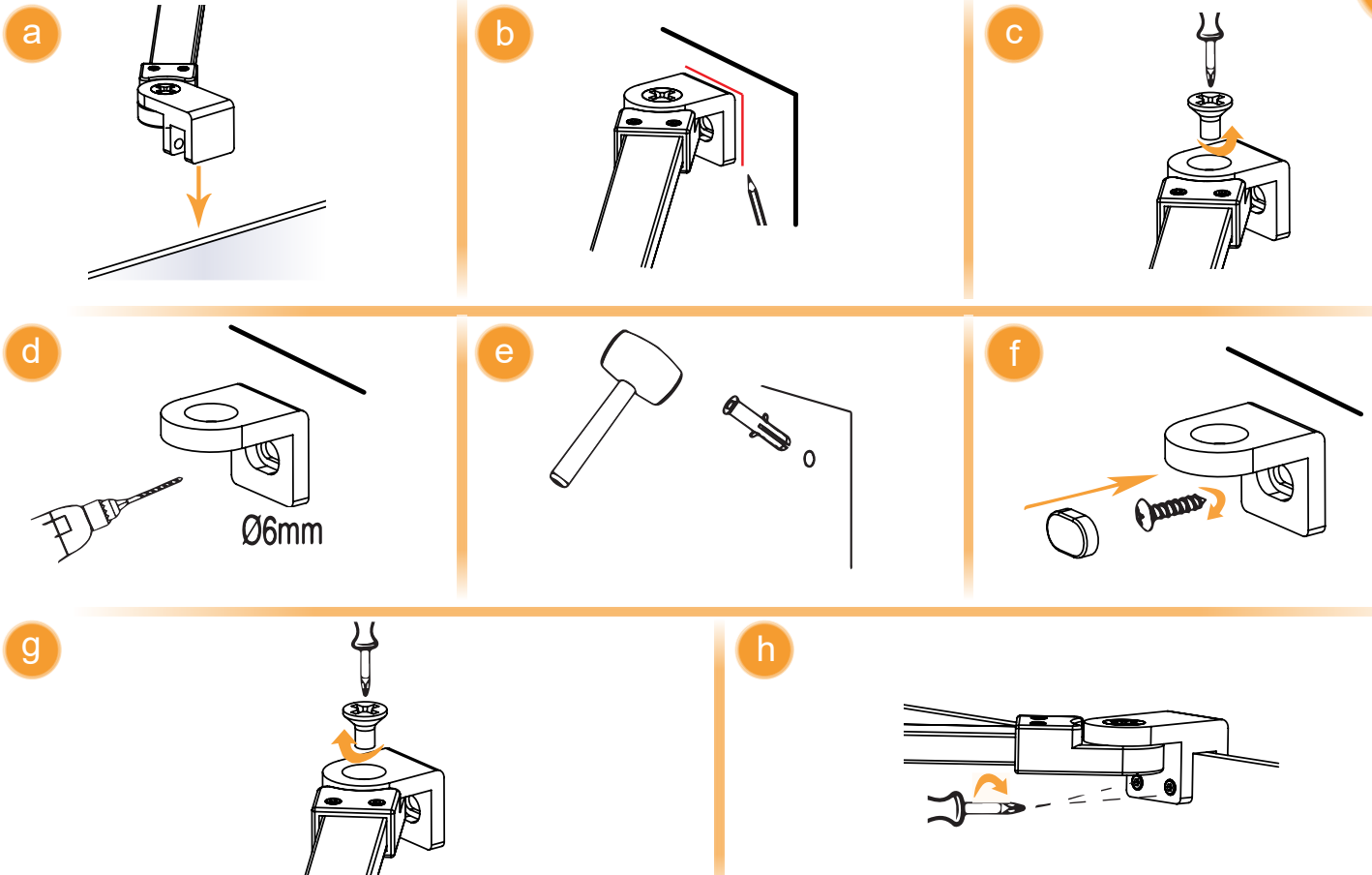
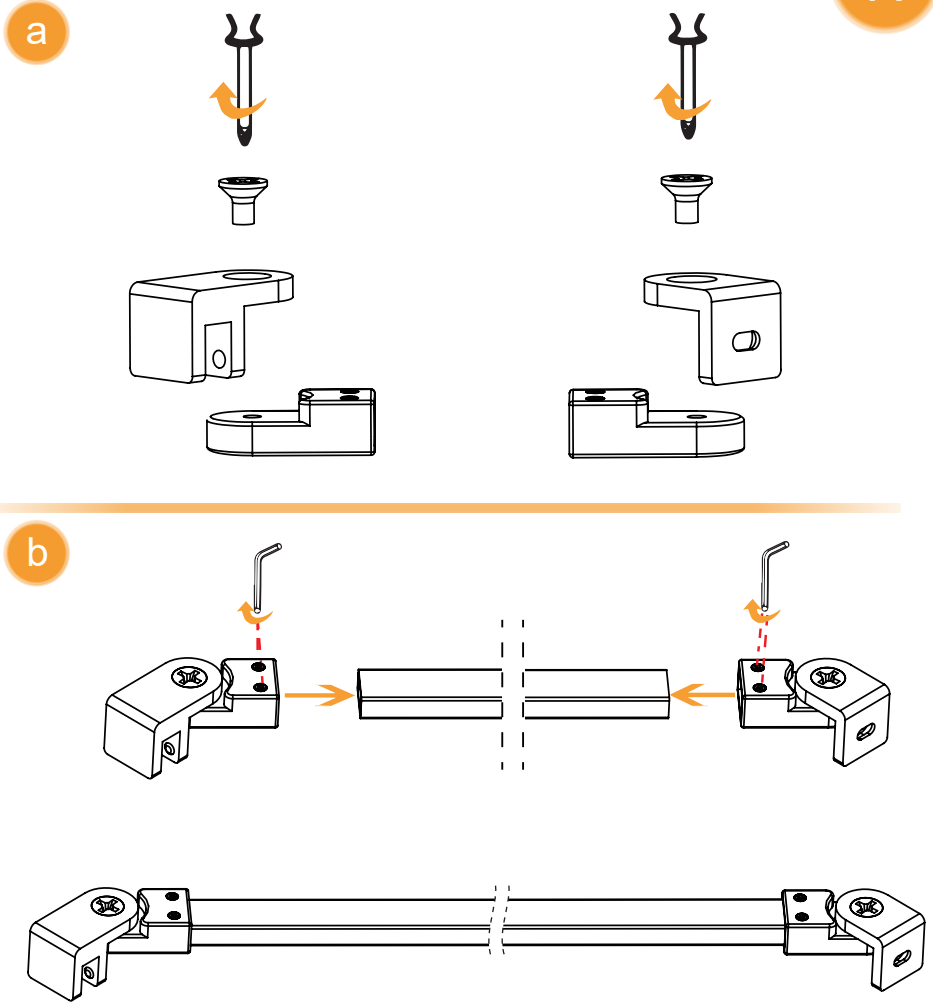
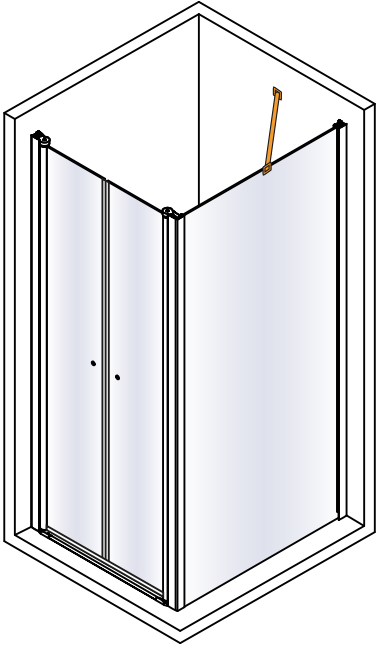

Opcja 2 - Option 2

(wspornik równoległy)

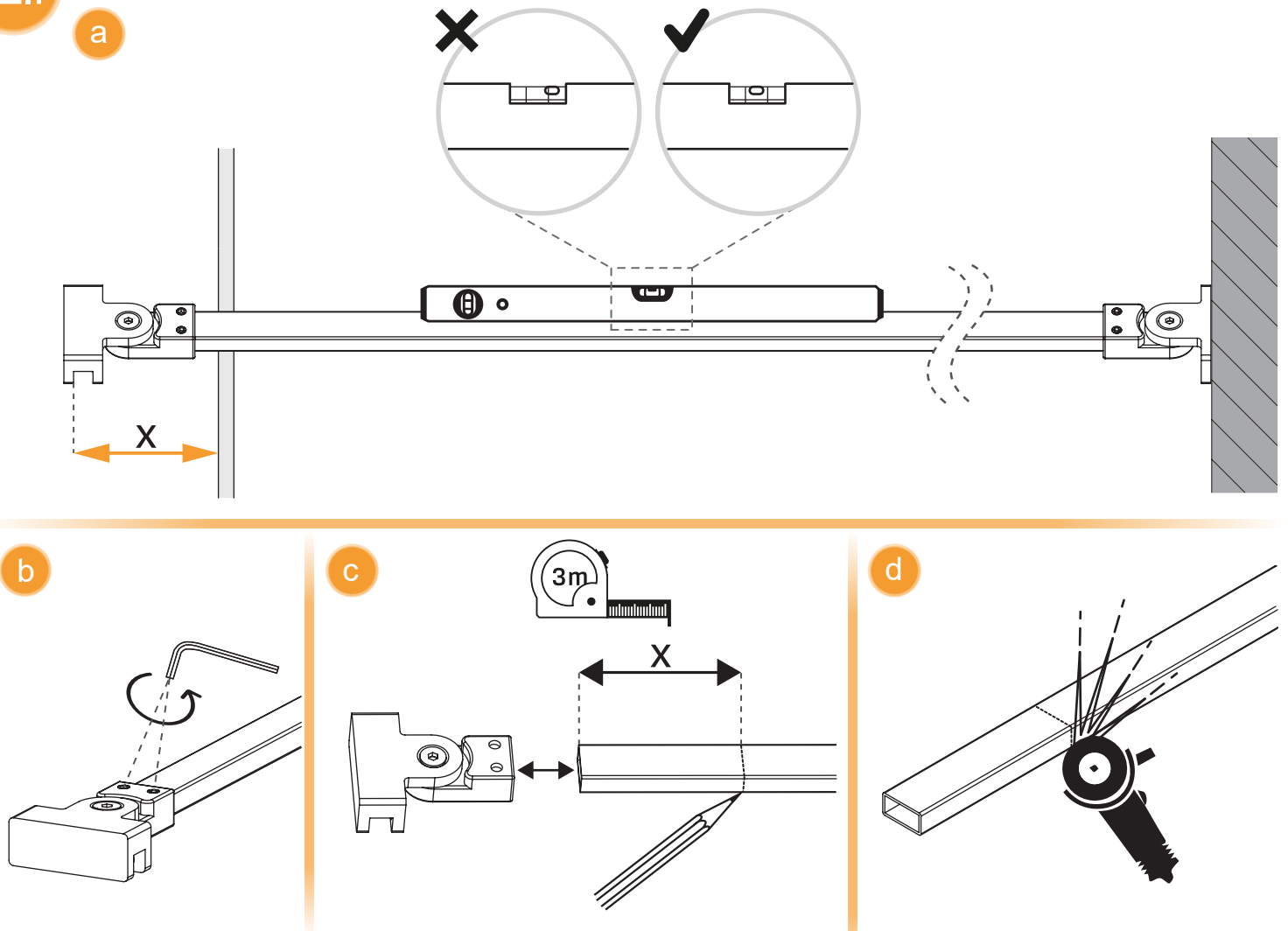
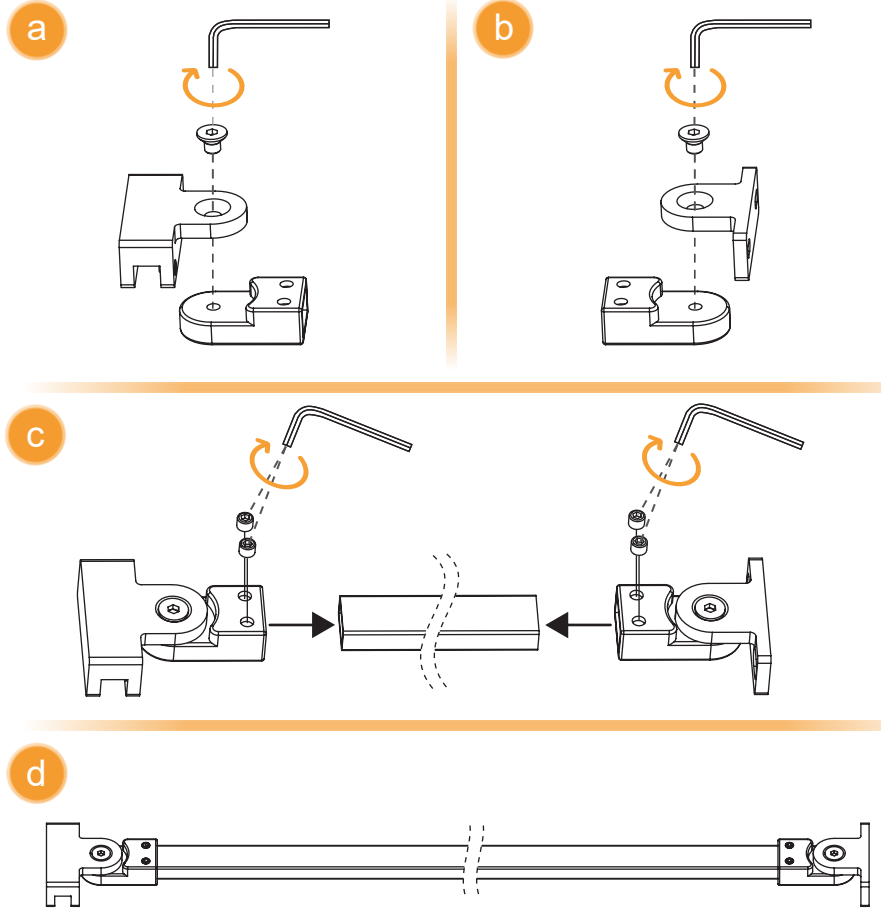
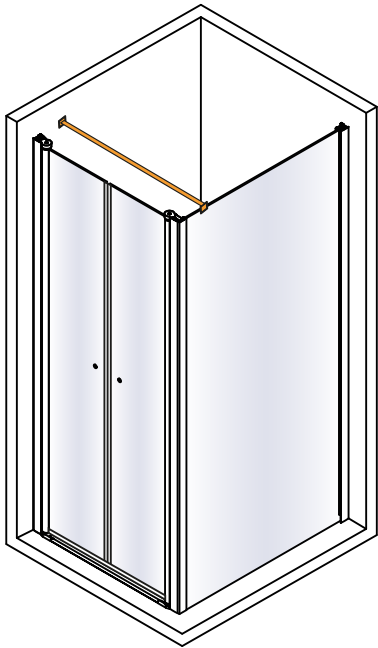

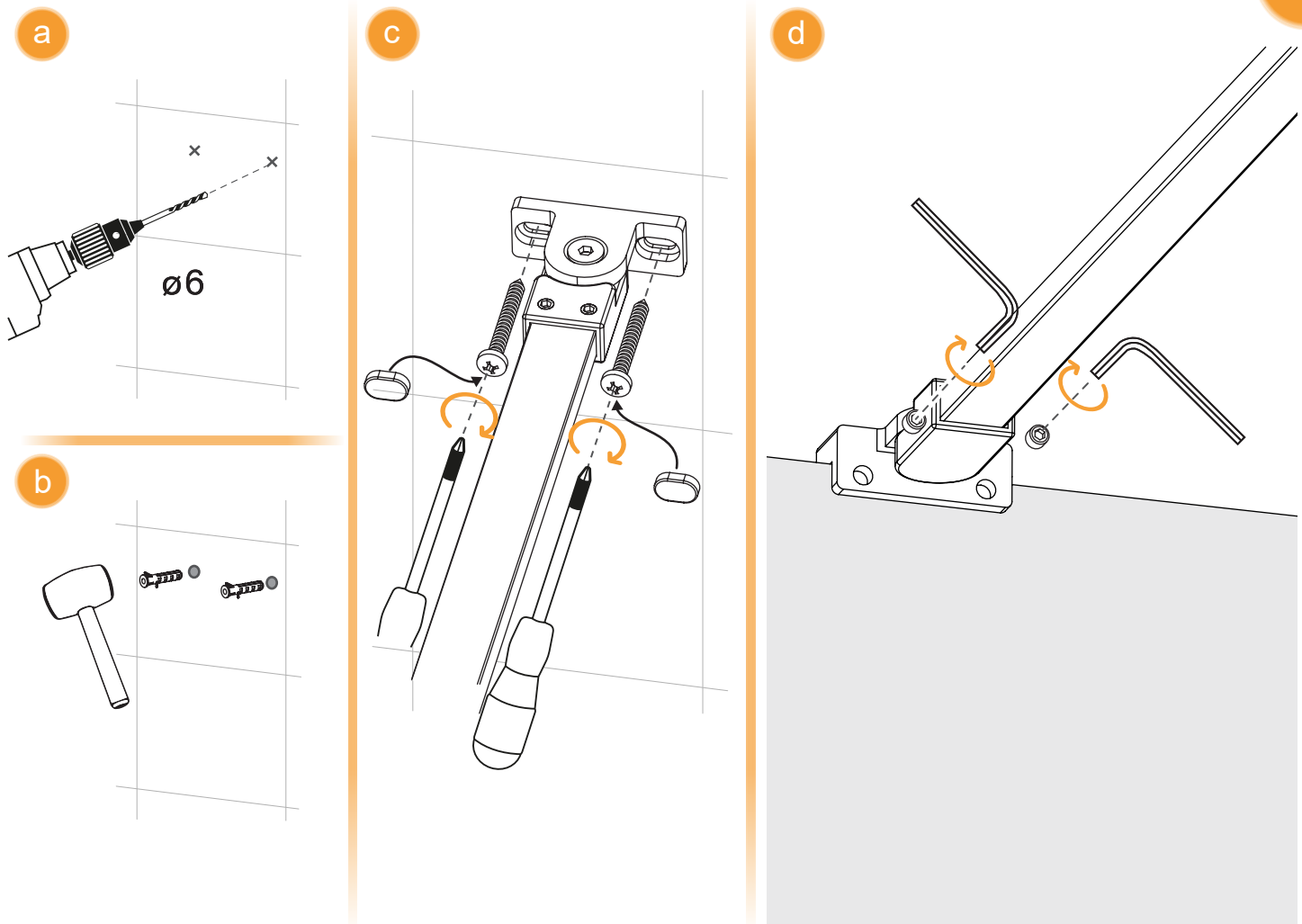
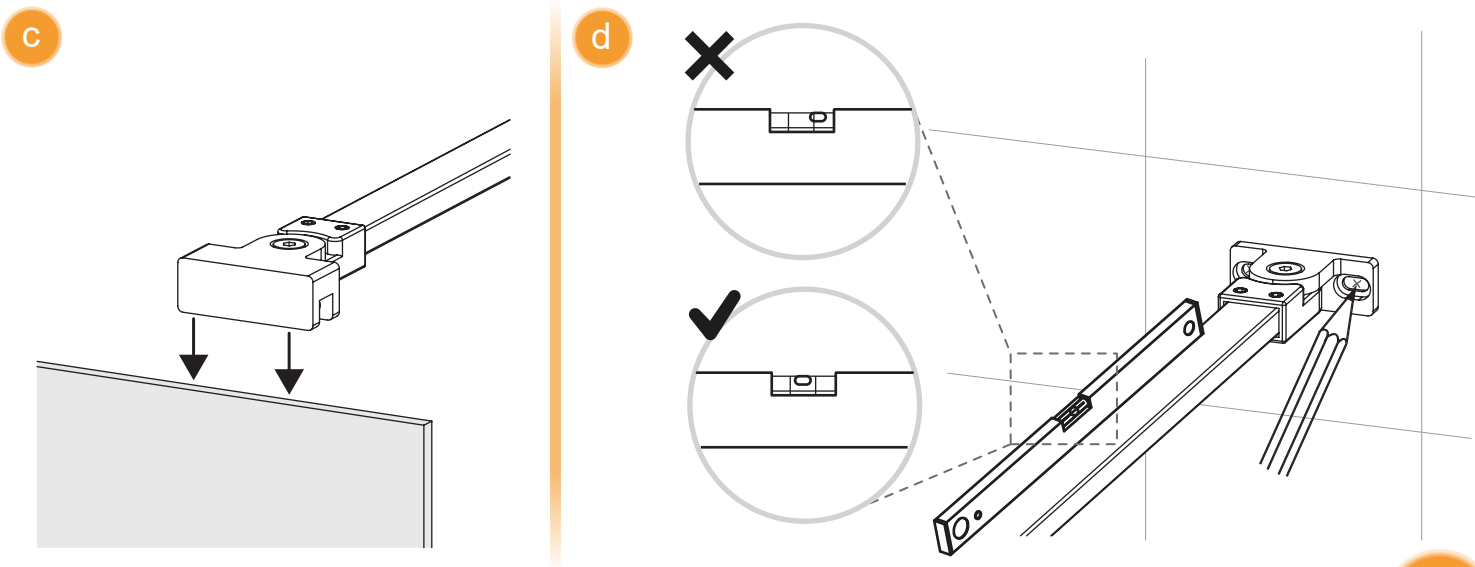
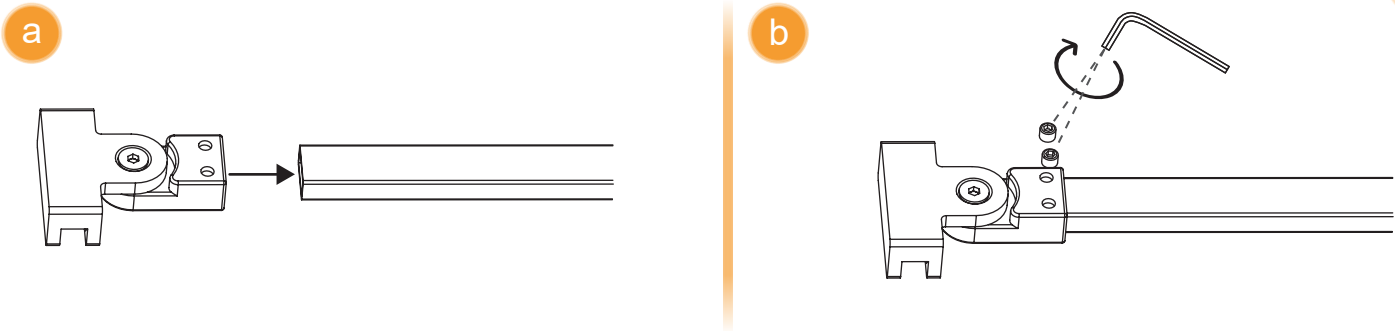

13

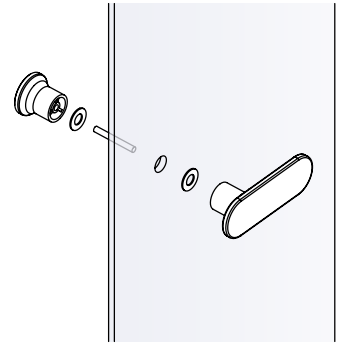
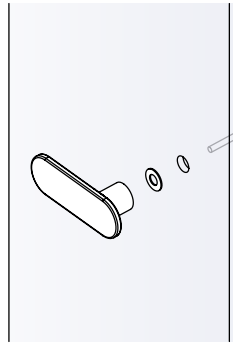
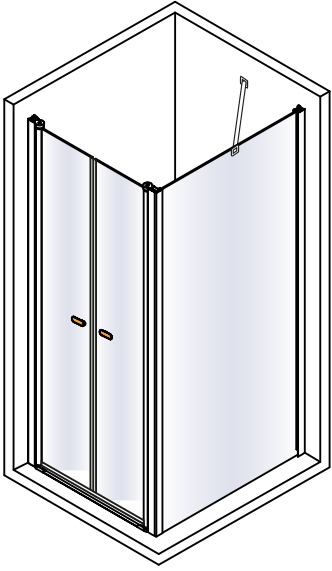

14

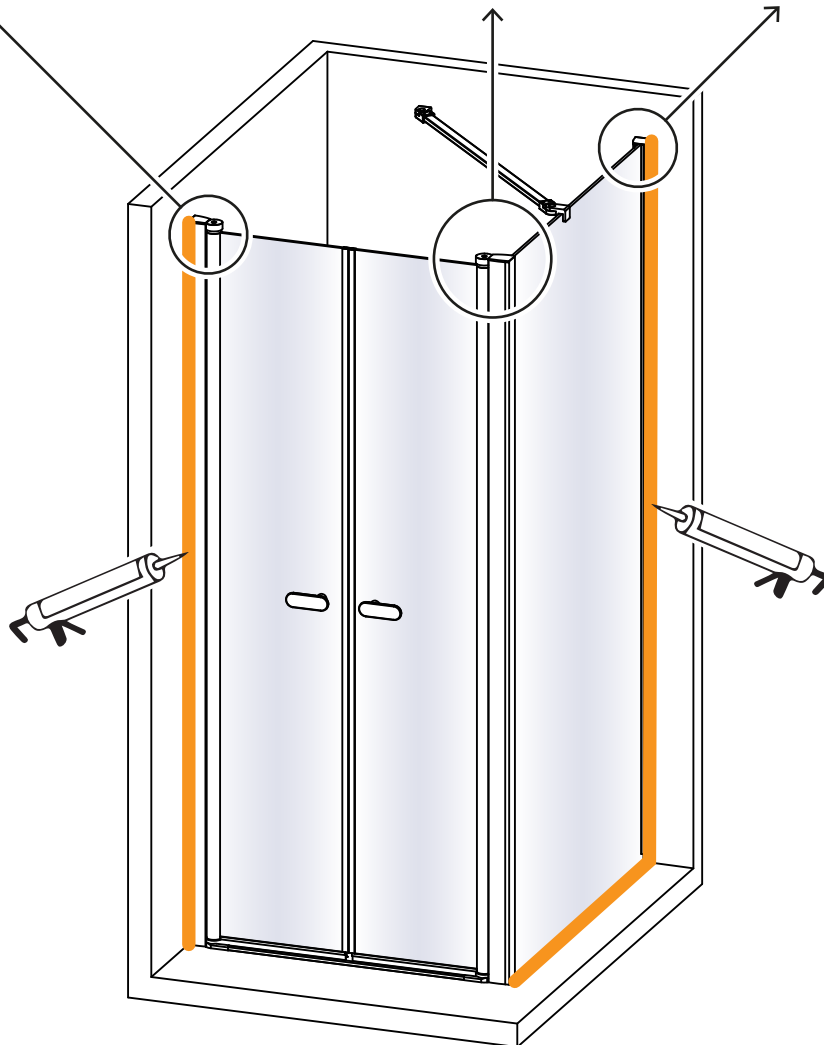
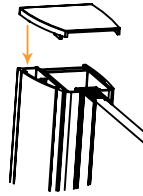
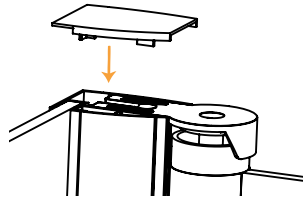
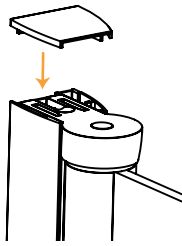

24H